

## 气缸头部件 CYLINDER HEAD ASSY

序号NO.	编码 (PART CODE)	中文名称 (CHINESE DESCRIPTION)	英文名称 (ENGLISH DESCRIPTION)	数量QTY	备注 Note
1	100100406-0002	Derbi125缸头盖固定螺栓(异形M6 兰白锌)	Screw, M6	3	
2	100094312	NC450缸头盖固定螺栓(异形M6×50.7)	Screw	3	
3	100102894	Derbi125头盖螺栓缓冲垫圈	Washer	6	
4	100104162	Derbi125火花塞孔密封圈	Spark Hole Gasket	1	
5	100124073	NC450S缸头盖密封圈	Seal Ring, Of Upper Cover Cylinder Head	1	1
6	100010839-0003	GB70.1螺栓M6×20(兰白锌)	Bolt, M6×20	2	
7	100724177	NC450节温器罩	Thermostat Cover	1	
8	100767957	NC450S节温器(2# 通气孔Φ2)	Thermostat	1	
9	100728067	NC450电喷冷却液温度传感器(三针带线)	Temperature Sensor	1	
10	100087291-0001	WH125缸头排气口双头螺栓M8×35(兰白锌)	Bolt, M8×35	2	
11	100124069-0002	NC450S气缸头盖(6813)	Upper Cover Cylinder Head	1	
12	100104640	PW70废气循环铁管纸垫	Paper Gasket	1	
13	100105429	CG125D二次进气口盖板	Intake Cover Board	1	
14	100055589-0006	GB16674小盘螺栓M6×16(兰白锌)	Bolt, M6×16	2	
15	100106566	平垫圈(Φ6.5×1.5×Φ12)	Washer, Φ6.5×1.5×Φ12	1	
16	100010837-0002	GB70.1螺栓M6×16(兰白锌)	Bolt, M6×16	1	
17	100033110-0002	GB16674小盘螺栓M6×25(兰白锌) 35CrMo P	Bolt, M6×25	2	
18	100721175-0002	NC450S气缸头组合(凯越款 M8 62 抛丸钝化)	Cylinder Head Assembly	1	
19	100715785	NC250S缸头出水嘴防尘胶套	rubber cover	1	
20	100762059	NC450S进气管卡箍组件(Φ74mm)	Clamp Inlet Pipe	1	
21	100762058	NC450S进气管卡箍组件(Φ75mm)	Clamp Inlet Pipe	1	
22					
23					
24					
25					
26					
27					
28					
29					
30					
31					
32					
33					
34					
35					
36					
37					
38					
39					
40					
41					
42					
43					
44					
45					

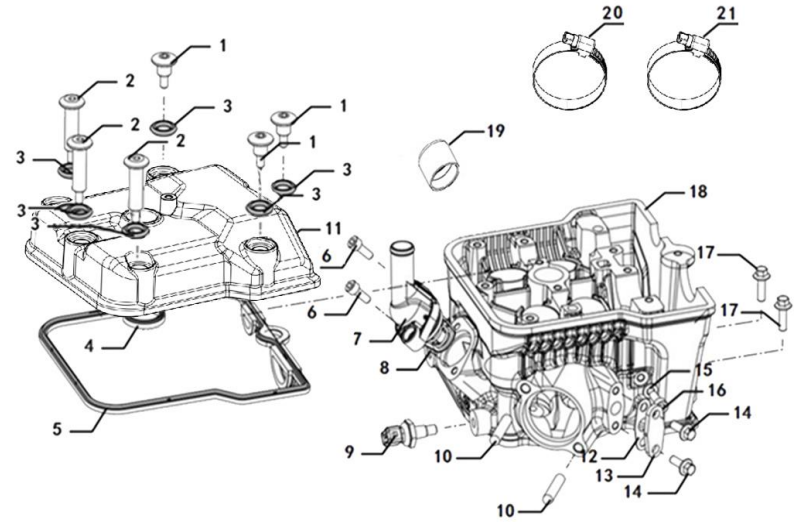

气缸头部件 CYLINDER HEAD ASSY

## 气缸体部件 CYLINDER ASSEMBLY

序号NO.	编码 (PART CODE)	中文名称 (CHINESE DESCRIPTION)	英文名称 (ENGLISH DESCRIPTION)	数量QTY	备注 Note
1	100104566	NC450气缸体密封垫(发泡金属橡胶复合板)	Gasket Cylinder Block	1	1
2	100108526	圆柱销 $\phi 6 \times 12$	Pin, $\phi 6 \times 12$	4	
3	100033110-0002	GB16674小盘螺栓M6×25(兰白锌) 35CrMo_P	Bolt, M6×25	2	
4	100124088	NC450S气缸头密封垫组合(金属)	Gasket Assy Cylinder Head	1	1
5	100108520	HIPER50张紧器密封垫	Gasket Tensioner	1	
6	100760013-0001	NC450S张紧器组合(2# 抛丸钝化)	Chain Tensioning Wheel	1	
7	100055588-0006	GB16674小盘螺栓M6×20(兰白锌)	Bolt, M6×20	2	
8	100124072-0001	NC450S气缸体部件(缸标449 抛丸钝化)	Cylinder Block Assembly	1	
9					
10					
11					
12					
13					
14					
15					
16					
17					
18					
19					
20					
21					
22					
23					
24					
25					
26					
27					
28					
29					
30					
31					
32					
33					
34					
35					
36					
37					
38					
39					
40					
41					
42					
43					
44					
45					

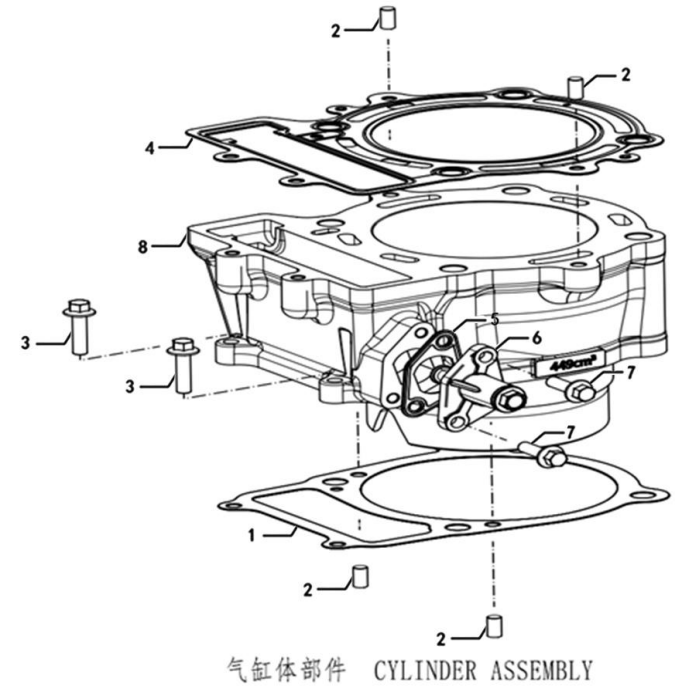

## 配气机构 VALVE MECHANISM

序号NO.	编码 (PART CODE)	中文名称 (CHINESE DESCRIPTION)	英文名称 (ENGLISH DESCRIPTION)	数量QTY	备注 Note
1	100051841	CB125脚气门锁夹(改进型)	Valve Locker	8	
2	100730259	NC450S气门弹簧上座	Spring Seat	4	
3	100730261	NC450S气门内弹簧	Inner Valve Spring	4	
4	100730260	NC450S气门外弹簧	Outer Valve Spring	4	
5	100105336	CG125D挡油罩组合	Seal Valve Stem	4	
6	100730262	NC450S气门外弹簧座圈	Outer Valve Spring Retainer	4	
7	100731050	NC450S排气门(杆径φ5.5)	Exhaust Valve	2	
8	100731051	NC450S进气门(杆径φ5.5)	Intake Valve	2	
9	100011537-0002	GB16674小盘螺栓M6×35(兰白锌)	Bolt, M6×35	6	
10	100105325	CG125D气门内弹簧座圈(下)	Spring Seat	4	
11	100064166	NC250电喷火花塞(NGK CR8E)	Spark Plug	1	10
12	100730352	NC450S气门挺柱(DLC涂层 φ30.5)	Valve Tappet	4	
13	100756168	NC450S减压阀复位扭簧	Decompression Spring, Of Camshaft	1	
14	100124092	NC450S排气凸轮轴减压阀甩块组合	Swing Piece Assemble	1	
15	100149788	NC250S凸轮轴减压阀挡板(φ6.5×2×φ25 兰白锌)	Washer, φ6.5×2×φ25	1	
16	100055589-0006	GB16674小盘螺栓M6×16(兰白锌)	Bolt, M6×16	1	
17	100748842	NC450S排气凸轮轴部件(链条加强)	Exhaust camshaft component	1	
18	100748841	NC450S进气凸轮轴部件(链条加强)	Intake camshaft component	1	
19	100748508	NC450S正时链条组合(5×134 齿形链)	Timing Chain	1	
20	100733674	NC450S链条张紧板组合(2#)	Tension Plate Assy	1	
21	100105211	NC450张紧板衬套	Bush	1	
22	100033090-0004	GB16674小盘螺栓M6×105(兰白锌)	Bolt, M6×105	1	
23	100124075	NC450S链条导向板组合	Guide Plate Chain	1	
24	100733757	NC450S链条压板(2#)	Clamp	1	
25	100033118-0007	GB16674小盘螺栓M6×40(兰白锌) 35CrMo P	Bolt, M6×40	2	
26	100104162	Derbi125火花塞孔密封圈	Spark Hole Gasket	1	
27	100758761	NC450S链条护板	Assembly Chain Protect Plate	1	
28	100055591-0006	GB16674小盘螺栓M6×12(兰白锌)	Bolt, M6×12	2	
29					
30					
31					
32					
33					
34					
35					
36					
37					
38					
39					
40					
41					
42					
43					
44					
45					

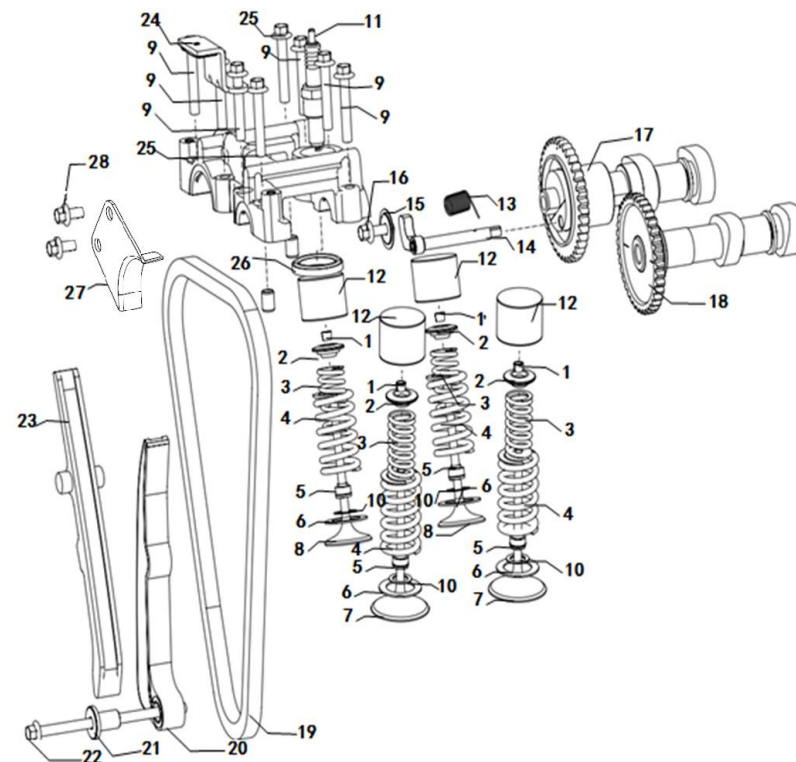

配气机构 VALVE MECHANISM

## 右曲轴箱盖 RIGHT CRANKCASE COVER

序号NO.	编码 (PART CODE)	中文名称 (CHINESE DESCRIPTION)	英文名称 (ENGLISH DESCRIPTION)	数量QTY	备注 Note
1	100031792-0003	GB70.1螺栓M6×30(兰白锌)	Bolt, M6×30	5	
2	100206182-0012	ZY150小视孔盖(内六角 抛丸钝化)	Cap Small View Hole	1	
3	100138362	O型圈(φ13.2×2.65 氟橡胶)	O-Ring, φ13.2×2.65	1	
4	100714002-0007	NC450右装饰盖组合(凯越款 带堵头 无喷油嘴 ZF-KY 抛丸钝化)	Right decorate cover assembly	1	1
5	100083675	NC450右装饰盖油嘴	fuel spray nozzle	1	
6	100087037	NC250右装饰盖密封垫(3# 发泡金属橡胶复合板)	Gasket Decotate Cover	1	1
7	100011537-0002	GB16674小盘螺栓M6×35(兰白锌)	Bolt, M6×35	11	
8	100104577	NC450右曲轴箱盖密封垫(发泡金属橡胶复合板)	Gasket R.Crankcase Cover	1	1
9	100102726	定位销φ9×13	Dowel Pin, φ9×13	2	
10	100069942	NC450水泵轴组合(2#)	Shaft Water Pump Ass.	1	
11	100104688	NC250曲轴油封(14×24×7 TCV型 氟橡胶)	Oil Seal 14×24×7	1	
12	100011077	GB893.1挡圈24	Retaining Ring, 24	1	
13	100107693	O型圈18×3.55(氟橡胶)	O-Ring, φ18×3.55	1	
14	100126228	NC250机油塞组合(2# 黑色 带1600ml标识)	Oil Plug Assy	1	
15	100104809	NC250水泵轴油封(12×24×6 氟橡胶)	Oil Seal 12×24×6	1	
16	100105543	NC450机械水封组件	Water Pump Seal	1	
17	100066800	NC450水泵叶轮	Ane Wheel Water Pump	1	
18	100069962	NC450水泵盖密封垫(发泡金属橡胶复合板)	Gasket	1	1
19	100070535-0003	NC450水泵盖(2# 抛丸钝化)	Water Pump Cover	1	1
20	100011534-0002	GB16674小盘螺栓M6×25(兰白锌)	Bolt, M6×25	2	
21	100106566	平垫圈(φ6.5×1.5×φ12)	Washer, φ6.5×1.5×φ12	1	
22	100011539-0001	GB16674小盘螺栓M6×45(兰白锌)	Bolt, M6×45	2	
23	100760470-0003	NC450S右盖组合(普通款 油冷孔螺纹M10×1.25 仅电白板 抛丸钝化)	Cover Comp Right Crankcase	1	1
24	100055589-0006	GB16674小盘螺栓M6×16(兰白锌)	Bolt, M6×16	2	
25	100107695	O型圈(φ19×1.8 丁腈胶)	O-Ring, φ19×1.8	1	
26	100731170	NC450S进水管接头	Pipe Joint	1	目前为老状态, 刚接收到联络, 后续走流程按新要求更改。
27	100106578	平垫圈(φ10×1×φ14)	Washer, φ10×1×φ14	2	
28	100204649-0001	AX100放油螺塞M10×1.25(兰白锌)	Oil Drain Plug	2	
29	100714175	NEXUS250电喷进出水口堵具	Plug	2	
30					
31					
32					
33					
34					
35					
36					
37					
38					
39					
40					
41					
42					
43					
44					
45					

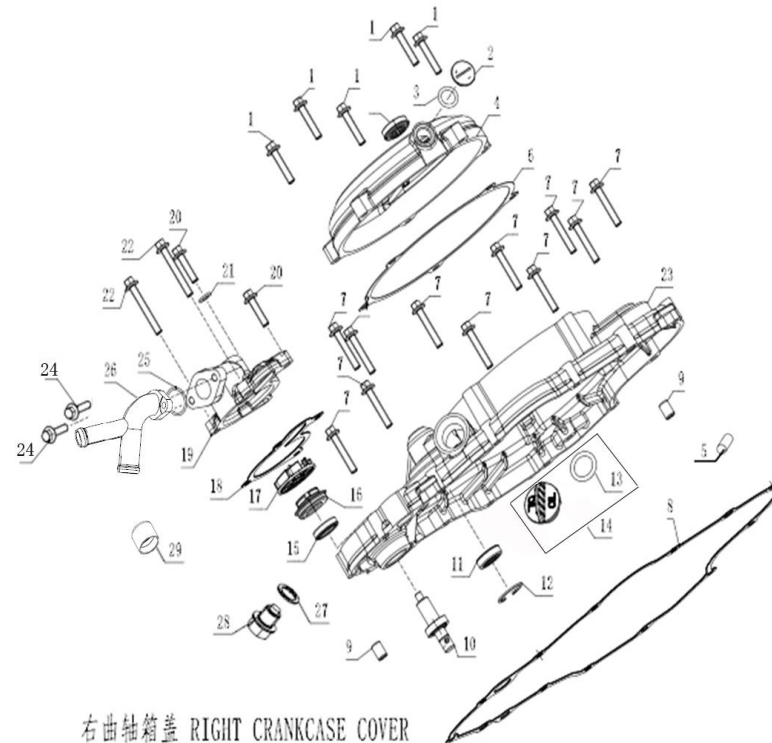

## 左曲轴箱盖 LEFT CRANKCASE COVER

序号NO.	编码 (PART CODE)	中文名称 (CHINESE DESCRIPTION)	英文名称 (ENGLISH DESCRIPTION)	数量QTY	备注 Note
1	100011537-0002	GB16674小盘螺栓M6×35(兰白锌)	Bolt, M6×35	1	
2	100011536-0002	GB16674小盘螺栓M6×30(兰白锌)	Bolt, M6×30	7	
3	100106566	平垫圈(φ6.5×1.5×φ12)	Washer, φ6.5×1.5×φ12	1	
4	100105195	NC250摇臂轴定位螺栓M14×1	Bolt	1	
5	100107654	O型圈(φ11.8×2.6 氟橡胶)	O-Ring, φ11.8×2.6	1	
6	100713816-0001	C100大视孔盖(φ24内径 抛丸钝化)	cover	1	
7	100107733	O型圈(φ27.4×2.65 氟橡胶)	O-Ring, φ27.4×2.65	1	
8	100713815-0006	NC450S左盖组合(普通款 ZF-KY 抛丸钝化)	left cover assembly	1	1
9	100104579	NC450左边盖密封垫(发泡金属橡胶复合板)	Gasket Cylinder Head Upper Cover	1	1
10	100102726	定位销φ9×13	Dowel Pin, φ9×13	2	
11	100104662	LY350换挡臂油封(14×26×6 氟橡胶)	Oil Seal 14×26×6	1	
12	100201333	CG125D空气泵进气口防尘胶套	Dust Bush	1	
13					
14					
15					
16					
17					
18					
19					
20					
21					
22					
23					
24					
25					
26					
27					
28					
29					
30					
31					
32					
33					
34					
35					
36					
37					
38					
39					
40					
41					
42					
43					
44					
45					

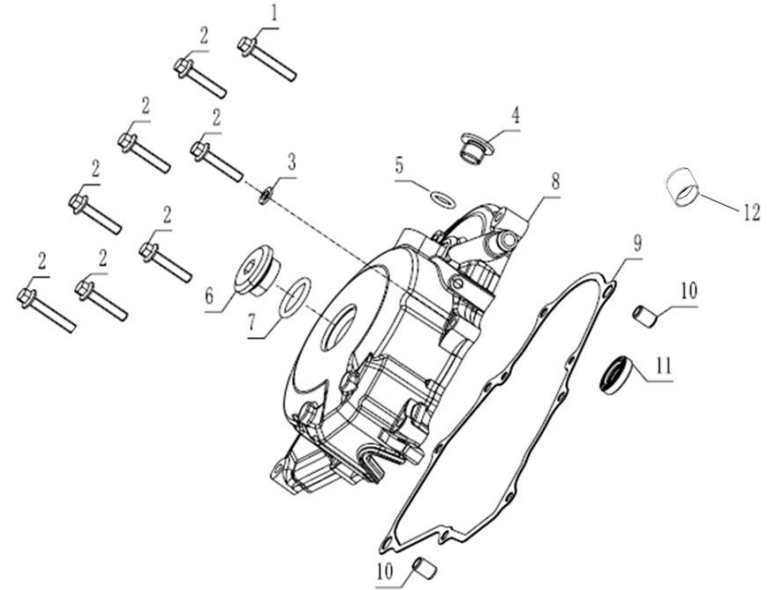

左曲轴箱盖 LEFT CRANKCASE COVER

## 离合器总成 CLUTCH ASSY

序号NO.	编码 (PART CODE)	中文名称 (CHINESE DESCRIPTION)	英文名称 (ENGLISH DESCRIPTION)	数量QTY	备注 Note
1	100106487	平垫圈(φ25×1.8×φ36)	Washer, φ25×1.8×φ36	1	
2	100090875	轴承(K25×29×10,滚针)	Needle BeaRing, (K25×29×10)	2	
3	100101254	轴承(K25×29×17,滚针)	Needle BeaRing, (K25×29×17)	1	
4	100103437	NC250离合器推杆	Pushing Rod Clutch	1	
5	100090873	NC450离合器顶杆(2#)	Rod Clutch Push(2#)	1	
6	100101204	GR125离合器止推轴承(Axk1528)	BeaRing, (Axk1528)	1	
7	100106415	平垫圈(φ15×1×φ28)	Washer, φ15×1×φ28	1	
8	100123227	NC450离合器主动摩擦片(富士离合器专用)	Drive Friction Disk	1	2
9	100123251	NC450离合器主动摩擦片(2#_富士离合器专用)	Drive Friction Disk	5	10
10	100123226	NC450离合器从动摩擦片(富士离合器专用)	Outer Friction Disk A	6	12
11	100123250	NC450离合器主动摩擦片(3#_富士离合器专用)	Drive Friction Disk	1	2
12	100125136	NC450离合器蝶形垫圈(富士离合器专用)	Dish Washer,Clutch	1	
13	100125141	NC450离合器蝶形垫圈衬座(富士离合器专用)	Line seat of Dish Washer,Clutch	1	
14	100125143	NC450离合器中心套(富士离合器专用)	Center Sleeve Clutch	1	
15	100125137	NC450离合器花键垫圈(富士离合器专用)	Washer	1	
16	100125142	NC450离合器外罩组合(富士离合器专用)	Out Case Assembly Clutch	1	
17	100125138	NC450离合器压盘螺栓(富士离合器专用)	Clutch disc bolt	5	
18	100125140	NC450离合器压盘(富士离合器专用)	Pressure Plate Clutch	1	
19	100125139	NC450离合器弹簧(富士离合器专用)	pressure plate clutch	5	
20	100098881	NC450离合器总成(3#_富士离合器)	Clutch Assy	1	
21	100121288	NC450离合器止推垫片	Stop Washer	1	
22	100059392	NC250主动齿锁紧螺母M18×1(2#)	Nut M18	1	
23					
24					
25					
26					
27					
28					
29					
30					
31					
32					
33					
34					
35					
36					
37					
38					
39					
40					
41					
42					
43					
44					
45					

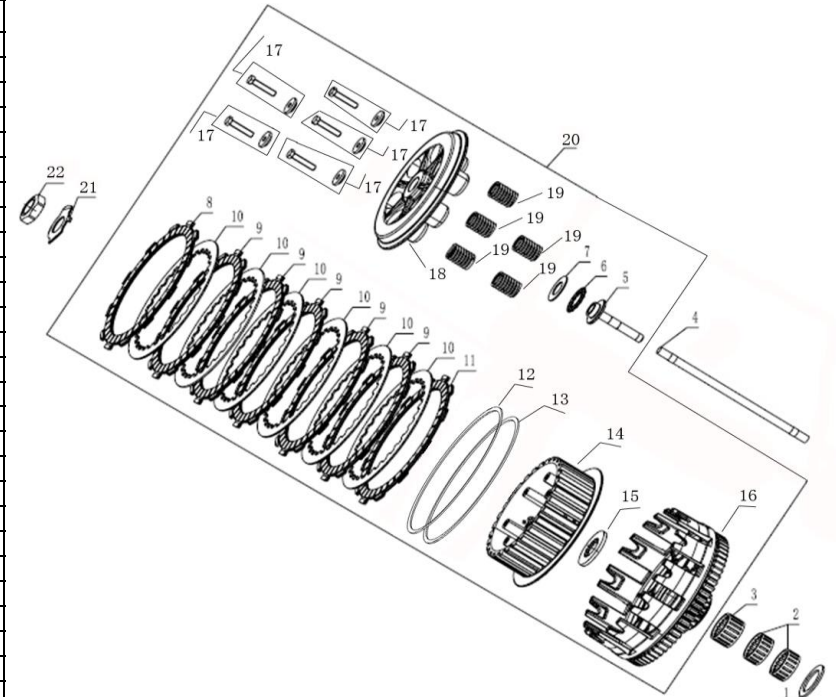

离合器总成 CLUTCH ASSY

## 机油泵部件 OIL PUMP

序号NO.	编码 (PART CODE)	中文名称 (CHINESE DESCRIPTION)	英文名称 (ENGLISH DESCRIPTION)	数量QTY	备注 Note
1	100011521-0001	GB16674小盘螺栓M5×18(兰白锌)	Bolt, M5×18	3	
2	100011094	GB894.1挡圈10(轴径10 内径9.3 RoHS)	Retaining Ring, 10	2	
3	100083712	NC450机油泵齿轮组合(2# PA46)	Oil Pump Gear Ass.	1	
4	100100903	圆柱销φ4×15.8	Pin, φ4×15.8	2	
5	100100168	NC250机油泵盖板(右)	Oil Pump Cover	1	
6	100100207	NC250机油泵外转子(一)	Outer Rotor Oil Pump	1	
7	100100196	NC250机油泵内转子(一)	Inner Rotor Oil Pump	1	
8	100100215	NC250机油泵转子组件(8mm)	Oil Pump Rotor	1	
9	100100157	NC250机油泵油泵轴	Shaft Oil Pump	1	
10	100100197	NC250机油泵内转子(二)	Inner Rotor Oil Pump	1	
11	100100208	NC250机油泵外转子(二)	Outer Rotor Oil Pump	1	
12	100100216	NC250机油泵转子组件(14mm)	Oil Pump Rotor	1	
13	100100167	NC250机油泵盖板(左)	Oil Pump Cover	1	
14	100011518-0001	GB16674小盘螺栓M5×12(兰白锌)	Bolt, M5×12	3	
15	100083711	NC450机油泵过桥齿轮(2# PA46)	Oil Pump Gear	1	
16	100106390	平垫圈(φ10.2×0.5×φ15)	Washer, φ10.2×0.5×φ15	2	
17	100756198	NC450机油泵过桥齿轮轴	Oil Pump Gear Shaft	1	
18	100100889	圆柱销φ3×16	Pin, φ3×16	1	
19	100754529	NC450机油泵过桥齿轮轴压板	Stop Plategear shaft	1	
20	100716947-0002	GB70.3螺栓M6×16(兰白锌) 10.9级	Bolt, M6×16	1	
21					
22					
23					
24					
25					
26					
27					
28					
29					
30					
31					
32					
33					
34					
35					
36					
37					
38					
39					
40					
41					
42					
43					
44					
45					

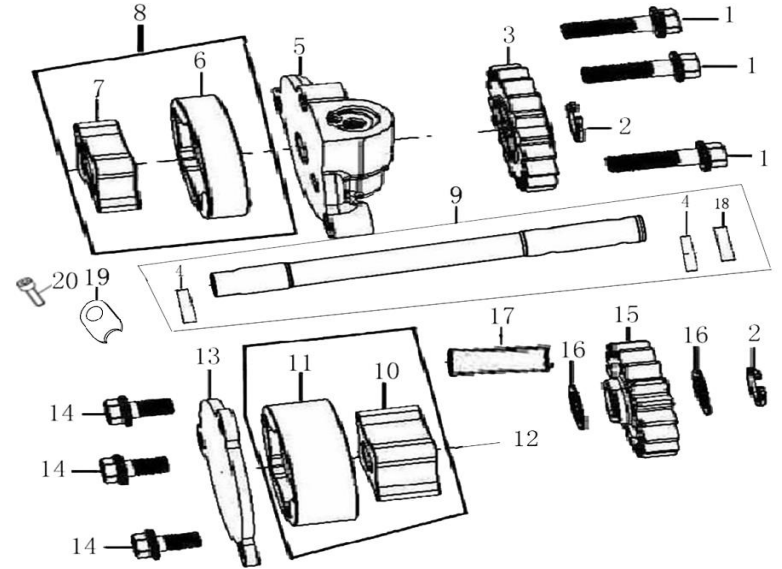

机油泵部件  
OIL PUMP



## 左曲轴箱 LEFT CRANKCASE

序号NO.	编码 (PART CODE)	中文名称 (CHINESE DESCRIPTION)	英文名称 (ENGLISH DESCRIPTION)	数量QTY	备注 Note
1	100071619-0001	GB16674.1小盘螺栓M6×70(兰白锌 35CrMo) 10.9级	Bolt, M6×70	3	
2	100071434-0001	GB16674.1小盘螺栓M6×65(兰白锌 35CrMo) 10.9级	Bolt, M6×65	3	
3	100033120-0001	GB16674小盘螺栓M6×45(兰白锌) 35CrMo_P	Bolt, M6×45	6	
4	100104487	CG125D档显动触头(2#)	Contact Cearindication	1	
5	100104494-0015	NC250六档档显线束(六档国际 接口6G-D99 L:500)	Gearshift Switch Comp	1	
6	100010979-0003	GB819.2螺钉M6×20(兰白锌)	Screw, M6×20	1	
7	100718367-0002	NC450左曲轴箱组合(2# 曲轴轴承孔带嵌件 凯越专用 抛丸钝化)	Left Crankcase Block	1	
8	100100726	NC250机油喷嘴	Oil Nozzle	1	
9	100107684	O型圈(φ17.5×1.8 氟橡胶)	O-Ring, φ17.5×1.8	1	10
10	100104918-0001	NC250机油滤网盖(黑锌)	Cover Oil Filter Screen	1	
11	100060838	NC250机油滤网组合(2# 带O型密封圈)	Strainer Oil Filter	1	10
12	100104830	LY350倒档变速鼓油封(15×25×5 氟橡胶)	Oil Seal 15×25×5	1	
13	100103518	NC450输出轴轴套	Bush	1	
14	100107725	O型圈(φ25×2 氟橡胶)	O-Ring, φ25×2	1	
15	100104814	LY350输出轴油封(35×45×6 氟橡胶)	Oil Seal 35×45×6	1	
16	100010771	轴承(61902-2Z)	Bearing, 61902	1	
17	100011078	GB893.1挡圈28	Retaining Ring, 28	1	
18	100100927	轴承(61805)	BeaRing, (61805)	1	
19	100100932	轴承(NJ205)	BeaRing, (Nj205)	1	
20	100300748	轴承(6303RS C3)	BeaRing, (6303Rs C3)	1	
21	100070092	轴承(NJ207EM C3)	BeaRing, (Nj207)	1	
22	100100999	轴承(6304 东培)	BeaRing, (6304)	1	
23	100068013	NC250轴承挡板	Baffle	1	
24	100010836-0006	GB70.1螺栓M6×12(兰白锌)	Bolt, M6×12	1	
25	100104747	CG125D档显油封(14×22×5 丙烯酸酯)	Oil Seal 14×22×5	1	
26	100086982-0001	NC450离合器分离杆(2# 兰白锌)	Clutch Separating Rod	1	
27	100770733-0001	ZF250X离合器分离杆摇臂(兰白锌)	Rocker Arm Release Lever Clutch	1	中心距50mm
28	100771005-0001	NC450气缸双头螺栓AB(M10×152 达克罗) 三价铬	Cylinder Stud Bolt A	2	
29	100106393	平垫圈(φ10.5×2×φ20 磷化)	Washer, φ10.5×2×φ20	2	
30	100106575	平垫圈(φ8.5×1.2×φ15)	Washer, φ8.5×1.2×φ15	1	
31	100032843-0004	GB70.1螺栓M8×12(兰白锌)	Bolt, M8×12	1	
32	100106556	平垫圈(φ16.5×2×φ23)	Washer, φ16.5×2×φ23	1	
33	100050705-0002	NC450放油螺栓M16×1.5(兰白锌)	Drain Bolt	1	
34					
35					
36					
37					
38					
39					
40					
41					
42					
43					
44					
45					

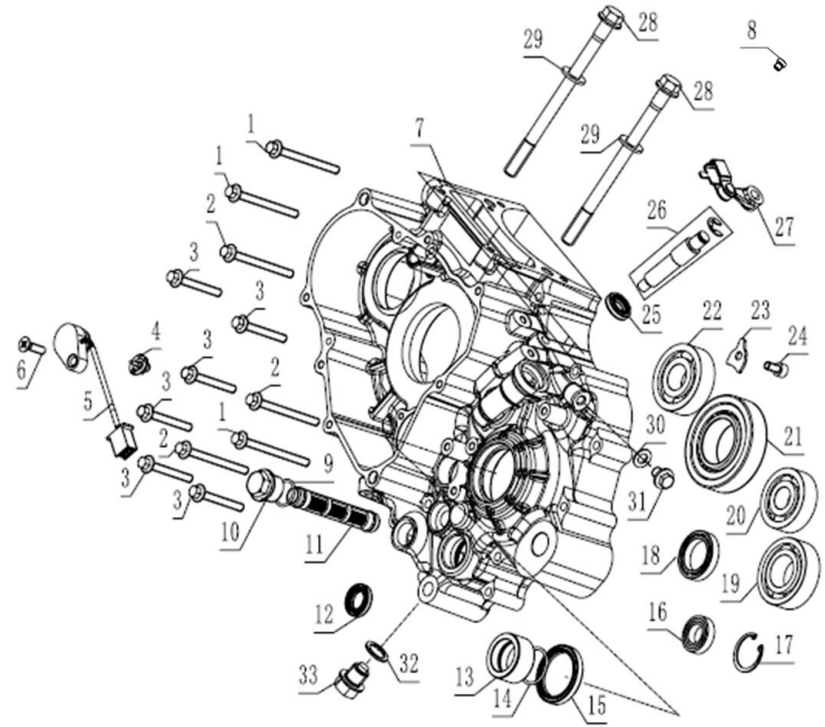

左曲轴箱 LEFT CRANKCASE



## 右曲轴箱 RIGHT CRANKCASE

序号NO.	编码 (PART CODE)	中文名称 (CHINESE DESCRIPTION)	英文名称 (ENGLISH DESCRIPTION)	数量QTY	备注 Note
1	100771005-0001	NC450气缸双头螺栓AB(M10×152 达克罗) 三价铬	Cylinder Stud Bolt A	2	
2	100106393	平垫圈(φ10.5×2×φ20 磷化)	Washer, φ10.5×2×φ20	2	
3	100300748	轴承(6303RS C3)	BeaRing, (6303Rs C3)	1	
4	100101252	轴承(6305 P5)	BeaRing, (6305 P5)	1	
5	100100927	轴承(61805)	BeaRing, (61805)	1	
6	100100999	轴承(6304 东培)	BeaRing, (6304)	1	
7	100070092	轴承(NJ207EM C3)	BeaRing, (Nj207)	1	
8	100068013	NC250轴承挡板	Baffle	2	
9	100010836-0006	GB70.1螺栓M6×12(兰白锌)	Bolt, M6×12	2	
10	100108525	定位销φ13×14	Dowel Pin, φ13×14	2	
11	100100398	NC250变档臂定位螺栓	Bolt Return Springn Fixing	1	
12	100010771	轴承(61902-2Z)	Bearing, 61902	1	
13	100104689	NC250右曲轴油封(35×50×7 丙烯酸酯)	Oil Seal 35×50×7	1	
14	100062066	C135曲轴油封20×30×5(氟橡胶)	Oil Seal 20×30×5	1	
15	100055589-0006	GB16674小盘螺栓M6×16(兰白锌)	Bolt, M6×16	2	
16	100063279-0003	NC250机油精滤器盖(2# 抛丸钝化)	Cap Oil Filter	1	
17	100107754	O型圈(φ30×2.6 氟橡胶)	O-Ring, φ30×2.6	1	10
18	100100017	NC250倒档精滤器弹簧	SpRing, Oil Fine Filter	1	
19	100104863	NC250倒档机油精滤器部件	Oil Filter	1	10
20	100104918-0001	NC250机油滤网盖(黑锌)	Cover Oil Filter Screen	1	
21	100107684	O型圈(φ17.5×1.8 氟橡胶)	O-Ring, φ17.5×1.8	1	
22	100060838	NC250机油滤网组合(2# 带O型密封圈)	Strainer Oil Filter	1	10
23	100033118-0007	GB16674小盘螺栓M6×40(兰白锌) 35CrMo P	Bolt, M6×40	1	10
24	100760469-0001	NC450S右曲轴箱组合(2# 曲轴轴承孔带嵌件_油冷孔螺纹M10×1.25 抛丸钝化)	Right Crankcase Block	1	
25					
26					
27					
28					
29					
30					
31					
32					
33					
34					
35					
36					
37					
38					
39					
40					
41					
42					
43					
44					
45					

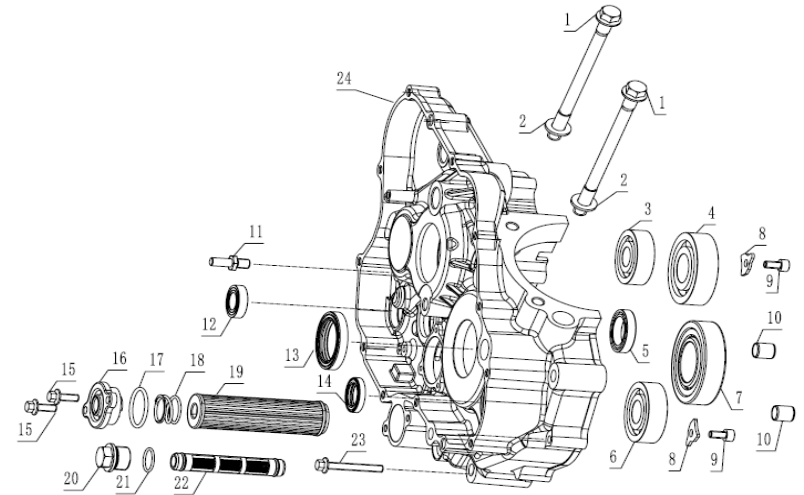

右曲轴箱 RIGHT CRANKCASE

## 曲轴连杆部件/活塞 CRANKSHAFT CONNECTING-ROD ASSY/PISTON

序号NO.	编码 (PART CODE)	中文名称 (CHINESE DESCRIPTION)	英文名称 (ENGLISH DESCRIPTION)	数量QTY	备注 Note
1	100759687	NC450S曲轴平键(4×4×16)	Tabulate Key	1	
2	100033053-0001	GB6170螺母M14×1.5(兰白锌)	Nut, M14×1.5	1	
3	100085912	NC450曲轴间隙调节垫圈 φ35×0.2×φ50	Washer, φ35×0.2×φ50	1	
4	100713372	NC450S活塞环总成	Piston Ring, Comp	1	1
5	100712823	NC450S活塞销挡圈	Piston pin retainer	2	
6	100124086	NC450S活塞	Piston	1	1
7	100712824	NC450S活塞销	Piston pin	1	
8	100059393	NC250平衡轴锁紧螺母M24×1(2#)	Nut M24	1	
9	100106369	平垫圈(φ24.2×2.5×φ32)	Washer, φ24.2×2.5×φ32	1	
10	100748770	NC450S曲轴正时主动链轮(链条加强)	Timing drive sprocket	1	
11	100120900	NC450平衡主动齿轮(2#)	Driving Gear	1	
12	100100650	NC250半圆键	Semicircular Key	1	
13	100100661	NC250曲轴平键(4×4×16)	Tabulate Key	1	
14	100756165	NC450曲轴连杆部件(2# 立多禄塑钻膜KU344322 镀铜)	Crankshaft Connecting-Rod Assy	1	
15	100095893	平垫圈(φ25×2×φ40)	Washer, φ25×2×φ40	1	
16	100101022	轴承(K29×33×20 滚针)	Needle BeaRing, (K29×33×20)	1	
17	100086987	NC450启动大齿轮组合(2#)	Plate Gear Assy	1	
18	100086989	NC450超越离合器部件	Assembly Overrunning Clutch	1	
19	100120901	NC450主动齿(2#)	Primary Drive Gear	1	
20	100059394	NC250主动齿止推垫圈(2#)	Stop Washer	1	
21	100059392	NC250主动齿锁紧螺母M18×1(2#)	Nut M18	1	
22	100059391	NC250离合器锁紧螺母(M16×1)	Lock Nut, Clutch	1	
23	100103345	CB125脚离合器碟形垫圈(16.5×2×27)	Dish Washer, Clutch	1	
24	100120899	NC450平衡从动齿轮组合(2#)	Driven Gear Ass.	1	
25	100103573	NC250曲轴轴套	Crankshaft Tube	1	
26	100100661	NC250曲轴平键(4×4×16)	Tabulate Key	1	
27	100087509	NC450平衡轴组合(3#)	Balance Shaft	1	
28	100085912	NC450曲轴间隙调节垫圈 φ35×0.2×φ50	Washer, φ35×0.2×φ50	1	
29					
30					
31					
32					
33					
34					
35					
36					
37					
38					
39					
40					
41					
42					
43					
44					
45					

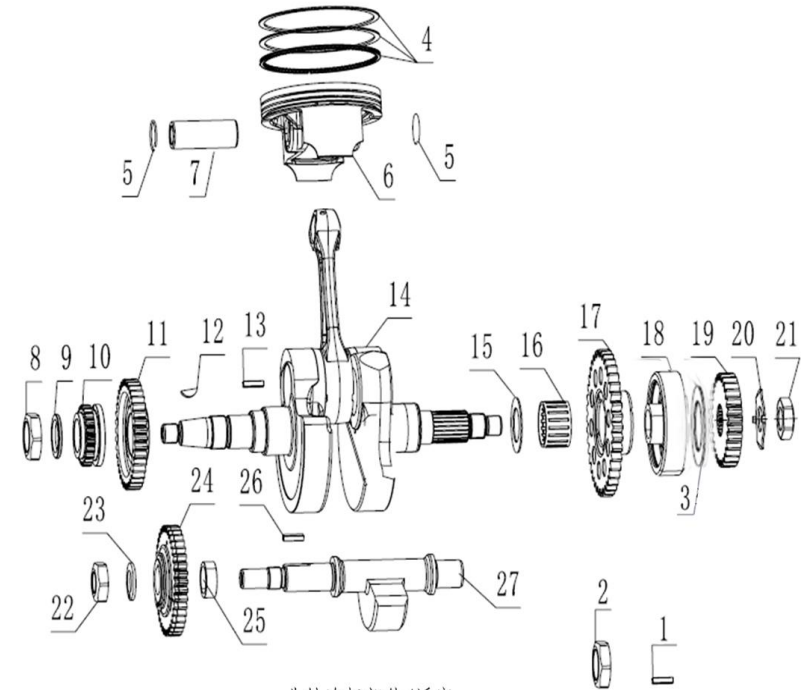

曲轴连杆部件/活塞  
CRANKSHAFT CONNECTING-ROD ASSY/PISTON

## 主副轴组合 TRANSMISSION MAIN,COUNTER SHAFT

序号NO.	编码 (PART CODE)	中文名称 (CHINESE DESCRIPTION)	英文名称 (ENGLISH DESCRIPTION)	数量QTY
1	100162378	NC450主轴组合(3#)	Main Shaft Transmission	1
2	100162430	NC450副轴组合(3#)	Countershaft Transmission	1
3	100090876	NC450主轴芯轴(2#)	Transmission Main Shaft	1
4	100162380	NC450主轴5档齿轮(3#)	Gear M-5	1
5	100078562	轴承(KS24×28×10TN_滚针_PA46)	Needle BeaRing, (Ks24×28×10Tn_PA46)	5
6	100106764	NC450主副轴齿轮隔圈(15齿)	Washer	5
7	100106772	NC450主副轴齿轮挡圈	Circlip	5
8	100162379	NC450主轴3(4)档齿轮(3#)	Gear M-3,4	1
9	100162381	NC450主轴6档齿轮(3#)	Gear M-6	1
10	100106752	NC450主轴2档齿轮	Gear M-2	1
11	100106441	平垫圈(φ17×1×φ32)	Washer, φ17×1×φ32	2
12	100106795	NC450副轴芯轴	Transmission Counter Shaft	1
13	100162383	NC450副轴2档齿轮(3#)	Gear C-2	1
14	100162387	NC450副轴6档齿轮(3#)	Gear C-6	1
15	100162384	NC450副轴3档齿轮(3#)	Gear C-3	1
16	100162385	NC450副轴4档齿轮(3#)	Gear C-4	1
17	100162386	NC450副轴5档齿轮(3#)	Gear C-5	1
18	100106467	平垫圈(φ20.1×1×φ30)	Washer, φ20.1×1×φ30	1
19	100162382	NC450副轴1档齿轮(3#)	Gear C-1	1
20	100101013	轴承(K20×24×10_滚针)	Needle BeaRing, (K20×24×10)	1
21	100162431	NC450主副轴组合(3#)	Transmission Main Counter Shaft	1
22	100066160	NC450主动链轮(520.13)	Drive Sprocket	1
23	100067277	NC450主动链轮止推垫圈(内花键)	Stop Washer	1
24	100058085	NC250主动链轮锁紧螺母M16×1(螺母带沉台)	Nut	1
25				
26				
27				
28				
29				
31				
32				
33				
34				
35				
36				
37				
38				
39				
40				
41				
42				
43				
44				
45				
46				

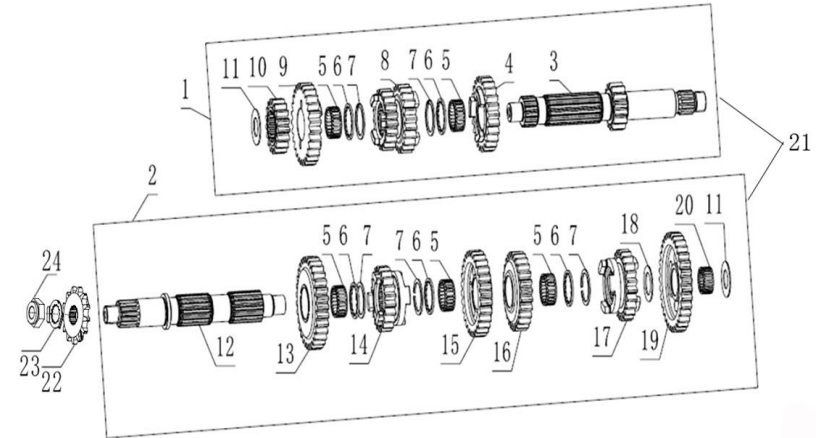

主副轴组合 TRANSMISSION MAIN,COUNTER SHAFT

## 变速机构 GEARSHIFT MECHANISM

序号NO.	编码 (PART CODE)	中文名称 (CHINESE DESCRIPTION)	英文名称 (ENGLISH DESCRIPTION)	数量QTY
1	100103964	NC250换挡臂部件	Gearshift Lever Comp	1
2	100104001	NC250换挡轴轴套	Axle Sleeve	1
3	100103973	NC250换挡回位弹簧	Return Spring	1
4	100203923	NC250换挡轴组合	Gearshift Shaft Comp	1
5	100103901	NC450副轴左拨叉	Left Fork Countershaft	1
6	100103897	NC450副轴右拨叉	Right Fork Countershaft	1
7	100103929	NC450副轴拨叉轴	Guide Pin, Selector Fork Center	1
8	100103979	NC250换挡板回位弹簧	SpRing, Gearshift Plate	1
9	100104487	CG125D档显动触头(2#)	Contact Cearindication	1
10	100103939	NC450变速鼓部件(六档国际档)	Gearshift Drum Comp	1
11	100103945	NC250倒档五星板	Stopping Plate	1
12	100011537-0002	GB16674小盘螺栓M6×35(兰白锌)	Bolt, M6×35	1
13	100103907	NC450主轴拨叉	Center Fork Mainshaft	1
14	100103921	NC250主轴拨叉轴	Shaft Gearshift Fork	1
15	100103988	NC250定位板弹簧(2#)	SpRing, Locating Plate	1
16	100104010	NC250定位板组合	Locating Plate Assy	1
17	100106379	平垫圈(Φ6.5×1.5×Φ18 磷化)	Washer, Φ6.5×1.5×Φ18	1
18	100055588-0006	GB16674小盘螺栓M6×20(兰白锌)	Bolt, M6×20	1
19				
20				
21				
22				
23				
24				
25				
26				
27				
28				
29				
30				
31				
32				
33				
34				
35				
36				
37				
38				
39				
40				
41				
42				
43				
44				
45				

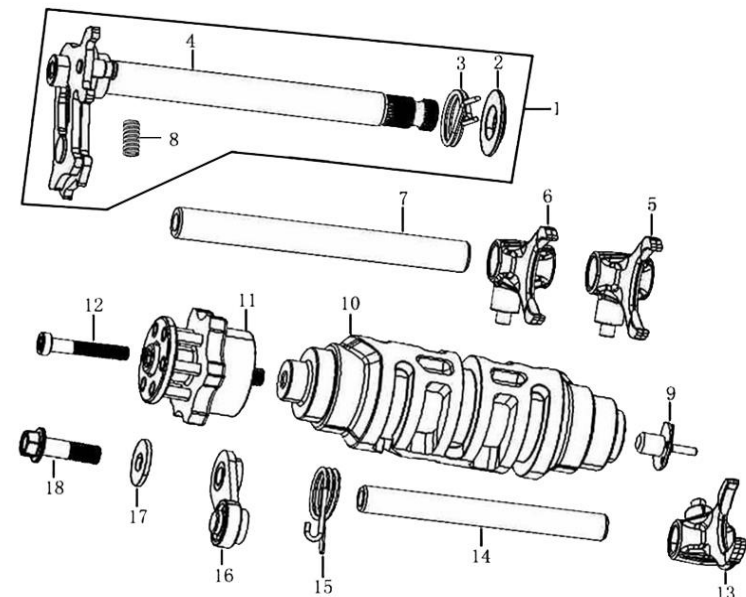

变速机构  
GEARSHIFT MECHANISM

## 磁电机总成 MAGNETO COMP

序号NO.	编码 (PART CODE)	中文名称 (CHINESE DESCRIPTION)	英文名称 (ENGLISH DESCRIPTION)	数量QTY	备注 Note
1	100746524-0002	NC450S磁电机定子组合(12V18极_三相全波整流_照明传感线束分叉_220mm处分叉_接口SQBZ-C20_L1:300)	Stator Assy, Magneto	1	
2	100731422	NC450S磁电机转子组合(12V18极_凸包个数22)	Stator Assy Magneto	1	
3	100010833-0001	GB70.1螺栓M5×25(兰白锌)	Bolt, M5×25	2	
4	100106421	平垫圈(φ15.2×1.5×φ25 磷化)	Washer, φ15.2×1.5×φ25	1	
5	100031788-0003	GB70.1螺栓M5×16(兰白锌)	Bolt, M5×16	2	
6					
7					
8					
9					
10					
11					
12					
13					
14					
15					
16					
17					
18					
19					
20					
21					
22					
23					
24					
25					
26					
27					
28					
29					
30					
31					
32					
33					
34					
35					
36					
37					
38					
39					
40					
41					
42					
43					
44					
45					

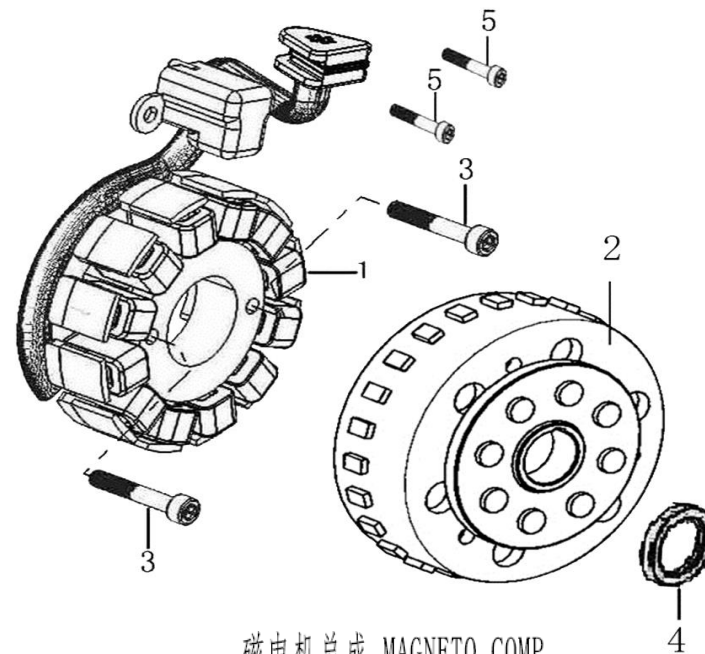

## 电启动机构 ELECTRIC STARTING MECHANI

序号NO.	编码 (PART CODE)	中文名称 (CHINESE DESCRIPTION)	英文名称 (ENGLISH DESCRIPTION)	数量QTY	备注 Note
1	100715179-0003	NC450S启动电机(单线_靴形34109-351B-0000_600_机座钝化_机壳兰白锌)	Starting Motor Assy	1	
2	100011534-0002	GB16674小盘螺栓M6×25(兰白锌)	Bolt, M6×25	2	
3	100083794	NC450双联齿轮组合一(2# 摩擦式)	Gear, Reduction, 1	1	
4	100062750	NC450双联齿轮轴(一)	Shaft Reduction	2	
5	100060120	NC450双联齿轮二(2#)	Gear, Reduction, 2(2#)	1	
6					
7					
8					
9					
10					
11					
12					
13					
14					
15					
16					
17					
18					
19					
20					
21					
22					
23					
24					
25					
26					
27					
28					
29					
30					
31					
32					
33					
34					
35					
36					
37					
38					
39					
40					
41					
42					
43					
44					
45					

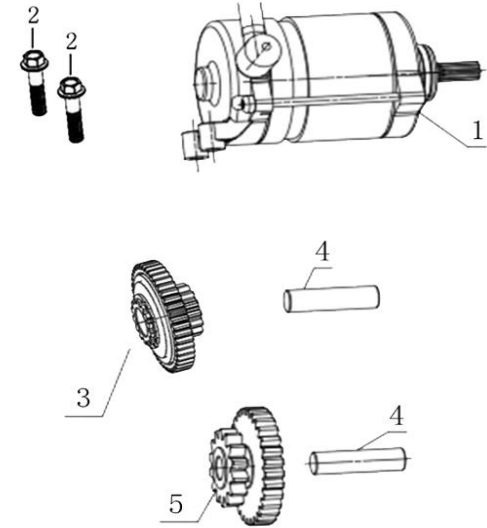

电启动机构 ELECTRIC STARTING MECHANI